

Aeron® Chairs

Prices effective December 7, 2009
Published June 2010

Introduction	page 2
Aeron® Chairs	3
Work Chair	5
Work Stool	8
Side Chair	11
Accessories	12
Appendices	
To view and/or print price book appendices, select the appropriate price book from HermanMiller.com .	

Introduction

A Note on the Organization of This Book

There are a few signals that will help you understand the organization of this book. Once you know them, you should be able to find your way around easily.

Like a newspaper, this book is formatted with columns of text and illustrations that run vertically.

Information wraps from one column to the next and continues for as many pages as it needs to.

Black bars are clues.

A black bar at the top of a page signals the start of information about a product.

This information is divided into two sections, each signaled by a black bar. Product Information includes a description, additional notes, and dimensional drawings. Specification Information, which always begins at the top of a column, includes a series of steps. Each step represents a decision you need to make in order to complete your product number. Steps must be followed sequentially. The number of pages needed to complete information on a product varies; some will be complete in one page; others may fill three or four pages. Just continue going through the steps until you run into the next product, signaled by the black bar at the top of the page.

Black tabs running along the outside edge of the page help you locate what section you are in or what section you want to go to. You can thumb forwards or backwards to find a section; tabs and text appear on both sides of the page.

The additional pages in the back of the book include the appendices and indices. They are signaled by a long black bar running along the outside edge of the page.

The index is presented two ways.

The first index is in alphabetical order by product name. It can be helpful if you are new to the products and numbering scheme or if you are looking for a type of product, such as work chair or round table.

The second index is by product number. It lists, in alphanumeric order, the base product number, typically a five-digit number.

General Information

This book is effective December 7, 2009, subject to change without notice. Products may be purchased from authorized Herman Miller dealers who will quote prices upon request. For more information about our products and services or to see a list of dealers, visit www.HermanMiller.com.

All prices are list prices. Additional services, such as planning services, design, storage, and installation, are not included and must be added to these prices when the additional services are requested.

Illustrations, specifications, and prices are based on the latest information at the time of publication. The right is reserved to make changes at any time without notice in prices, fabrics, finishes, materials, specifications, and models, and also to discontinue models and finishes.

Dimensions shown in the drawings are engineering drawing dimensions rounded up to the nearest $\frac{1}{8}$ ". Product is shipped set up or knocked down. Products that include "Shipped knocked down" in the description require some assembly. If this statement does not appear in the description, the product is shipped assembled.

Service problems are normally handled by a Herman Miller authorized dealer. Where this cannot be accomplished on a local level, service problems should be referred to the Customer Care Representative for your region, Herman Miller, Inc., Zeeland, Michigan 49464.

20-Day or Less/Assigned Lead-Time Shipments

All products and options in this price book not designated by an Assigned Program icon  will ship in **20 business days or less** after being acknowledged by Herman Miller.

Products and options designated by an  are on the assigned lead-time program and may ship in 20 days, less than 20 days, or more than 20 days from order acknowledgement.

Work Chair

Work Stool

Side Chair

Accessories

Work Chair

AE111
AE112
AE113



Product Information

Description

This chair has 3 sizes and a Pellicle® material that conforms to the user's body and retains its original shape when unoccupied. The material is lightweight and breathable and distributes the user's weight evenly over the seat and back of the chair. The chair has pneumatic height adjustment and a Kinemat® tilt that lets the body naturally pivot at the ankles, knees, and hips.

Tilt options include a tilt limiter that allows the user to select the tilt range to limit the amount of recline; a tilt limiter and seat angle that allows the user to select the tilt range and a horizontal or 5° forward seat angle; or a standard tilt.

Back-support options include PostureFit® support and an adjustable lumbar support. The PostureFit support provides a custom fit in the lower back area, below the beltline, that helps achieve healthier posture and improved lower back comfort. The user can adjust the level of support with a lever.

Arm choices include a fixed, nonadjustable option; a height-adjustable option that moves the arms 4" vertically; and a fully adjustable option that moves the arms 4" vertically and pivots the armpads 15° outward and 17½° inward.

The ZB, WS, and G8 base/frame finishes include a frame applique.

These appliques are applied to an Aeron work chair's seat, back, and arms to minimize the effect of contact between the chair and a wood-edge surface. The G8 option does not include an arm coating. The applique is only available on B- and C-size work chairs.

The frame applique options (ZB, WS, and G8) do not meet CAL 133 requirements. A fire retardant chair meets CAL 133 requirements. The chair's Pellicle material is manufactured with a fire-retardant additive.

Notes

To help determine chair size, see Aeron Chair Size/Fit Reference in Appendices. A-, B-, and C-size chairs are tested and warranted for use by persons 300 pounds and under.

For information on casters and glides, see Casters and Glides in Appendices.

PostureFit support is not available on standard tilt option.

Customer's Own Leather (COL) can be applied to armpads; requires 4 square feet. See Order Information in Appendices.

Dimensions

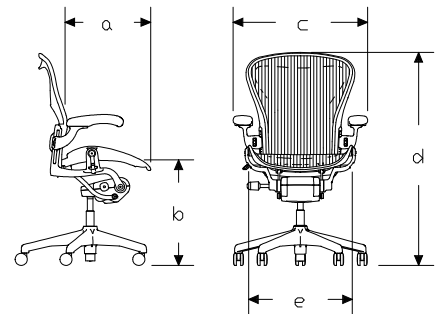

	Size A	Size B	Size C
a	15 3/4	17	18 1/2
b	14 3/8-19 1/2	15-20 7/8	15-20 7/8
c	25 3/4	27	28 1/4
d	41 max	42 max	45 max
e	19	20 1/4	21 5/8

All dimensions are in inches.

Specification Information	
Step 1.	
AE11	
Step 2. Tilt	
1	standard tilt
2	tilt limiter
3	tilt limiter and seat angle
Step 3. Arms	
N	no arms
P	fixed arms
H	height-adjustable arms
A	fully adjustable arms
Step 4. Armpad Upholstery	
<i>For no arms (N)</i>	
N	no arms
<i>For fixed arms (P), height-adjustable arms (H), or fully adjustable arms (A)</i>	
W	nonupholstered armpads
F	leather armpads
Step 5. Size	
A	a size
B	b size
C	c size
Step 6. Fire Retardancy	
<i>For not fire retardant (*), skip this step.</i>	
FR	fire retardant A

Prices for Steps 1-6.							
		A*	AFR	B*	BFR	C*	CFR
AE111	N N	\$932	932	932	932	932	932
	P W	\$1058	1058	1058	1058	1058	1058
	F	\$1103	1103	1103	1103	1103	1103
	H W	\$1121	1121	1121	1121	1121	1121
	F	\$1167	1167	1167	1167	1167	1167
	A W	\$1156	1156	1156	1156	1156	1156
	F	\$1201	1201	1201	1201	1201	1201
AE112	N N	\$990	990	990	990	990	990
	P W	\$1116	1116	1116	1116	1116	1116
	F	\$1161	1161	1161	1161	1161	1161

H W	\$1179	1179	1179	1179	1179	1179
F	\$1224	1224	1224	1224	1224	1224
A W	\$1213	1213	1213	1213	1213	1213
F	\$1259	1259	1259	1259	1259	1259
AE113	N N	\$1053	1053	1053	1053	1053
	P W	\$1179	1179	1179	1179	1179
	F	\$1224	1224	1224	1224	1224
	H W	\$1242	1242	1242	1242	1242
	F	\$1287	1287	1287	1287	1287
	A W	\$1277	1277	1277	1277	1277
	F	\$1321	1321	1321	1321	1321

Step 7. Back Support Option

<i>For standard tilt (1)</i>	
N2	no additional support +\$0
AJ	adjustable lumbar support +\$60

<i>For tilt limiter (2) or tilt limiter and seat angle (3)</i>	
N2	no additional support +\$0
AJ	adjustable lumbar support +\$60
PJ	adjustable PostureFit® support +\$95

Step 8. Base/Frame Finish

<i>For a size (A) with not fire retardant</i>	
G1	graphite +\$0
XT	titanium with smoke frame +\$0
CD	polished aluminum with graphite frame A +\$300

<i>For b size (B) or c size (C) with not fire retardant</i>	
G1	graphite +\$0
XT	titanium with smoke frame +\$0
WS	titanium with smoke frame and smoke applique +\$134
ZB	graphite with graphite applique +\$134
CD	polished aluminum with graphite frame A +\$300
G8	polished aluminum with graphite frame and graphite applique A +\$434

<i>For fire retardant (FR)</i>	
G1	graphite +\$0
CD	polished aluminum with graphite frame A +\$300

Step 9. Casters/Glides		
BB	2½" hard caster, black yoke, carpet	+\$0
GF	2½" glide, hard floors or carpet	+\$0
C7	2½" caster, black yoke, hard floors or carpet	+\$40
C9	2½" braking caster, black yoke, hard floors or carpet	+\$40

Step 10. Armpad Finish		
<i>For nonupholstered armpads (W) with graphite (G1), graphite with graphite applique (ZB), polished aluminum with graphite frame (CD), or polished aluminum with graphite frame and graphite applique (G8)</i>		
BK	black	+\$0

<i>For nonupholstered armpads (W) with titanium with smoke frame (XT) or titanium with smoke frame and smoke applique (WS)</i>		
S8	smoke	+\$0

Step 11. Pellicle® Material		
<i>See application chart and textiles list for material usage and numbers. First 2 digits of number indicate material; remaining 2 digits indicate color.</i>		

<i>For not fire retardant</i>		
Price Category 1		+\$0
Price Category 2		+\$25

<i>For fire retardant (FR) with graphite (G1) or polished aluminum with graphite frame (CD)</i>		
Price Category 1		+\$0

Step 12. Armpad Leather		
<i>For fixed arms (P), height-adjustable arms (H), or fully adjustable arms (A) with leather armpads (F)</i>		
<i>See application chart and textiles list for fabric usage and numbers. First 2 digits of number indicate fabric line; remaining digit(s) indicate fabric color.</i>		
Price Category 7		+\$0
Price Category 9		+\$75

Work Stool

AE711
AE712
AE713
AE721
AE722
AE723

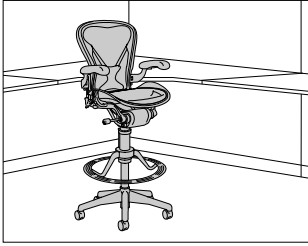

Aeron® Work Stool

Product Information

Description

This work stool has a Fine-Tune™ footring mechanism that allows the user to adjust the height of the footring from a seated position and reduces the pressure on the underside of the user's thighs. It has a 5-star base, pneumatic seat-height adjustment, and 2 height options. The low stool has a seat-height range of 24½" to 29" with a Fine-Tune footring that adjusts 2½" (from 15" to 17½" from the seat). The high stool has a seat-height range of 27½" to 34" with a Fine-Tune footring that adjusts 5½" (from 15" to 20½" from the seat). The high stool provides a wider range of height adjustment than does the low stool. The work stool is available in size B.

The stool has a Pellicle® material that conforms to the user's body and retains its original shape when unoccupied. The material is lightweight and breathable and distributes the user's weight evenly over the seat and back of the stool. The stool's Kinemat® tilt lets the body naturally pivot at the ankles, knees, and hips.

Tilt options include a tilt limiter that allows the user to select the tilt range to limit the amount of recline; a tilt limiter and seat angle that allows the user to select the tilt range and a horizontal or 5° forward seat angle; or a standard tilt.

Back-support options include PostureFit® support and an adjustable lumbar support. The PostureFit support provides a custom fit in the lower back area, below the beltline, that helps achieve healthier posture and improved lower back comfort. The user can adjust the level of support with a lever.

Arm choices include a fixed, nonadjustable option; a height-adjustable option that moves the arms 4" vertically; and a fully adjustable option that moves the arms 4" vertically and pivots the armpads 15° outward and 17½° inward.

The ZB, WS, and G8 options include a frame applique. These appliques are applied to an Aeron work stool's seat, back, and arms to minimize the effect of contact between the stool and a wood-edge surface. The G8 option does not include an arm coating.

The work stool and the frame applique options (ZB, WS, and G8) do not meet CAL 133 requirements.

Notes

Work stools are tested and warranted for use by persons 300 pounds and under.

For information on casters and glides, see Casters and Glides in Appendices.

Fine-Tune footring's polymer cover matches the frame finish.

PostureFit support is not available on standard tilt option.

Customer's Own Leather (COL) can be applied to armpads; requires 4 square feet. See Order Information in Appendices.

Dimensions

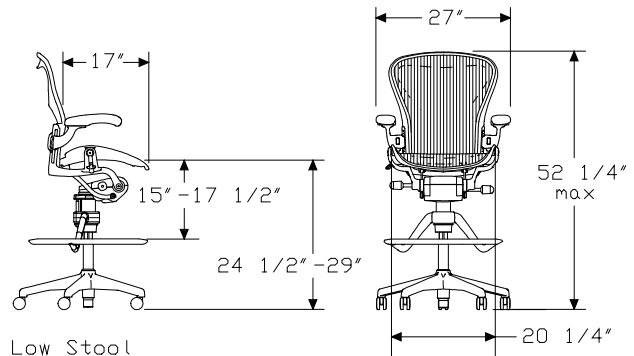

Low Stool

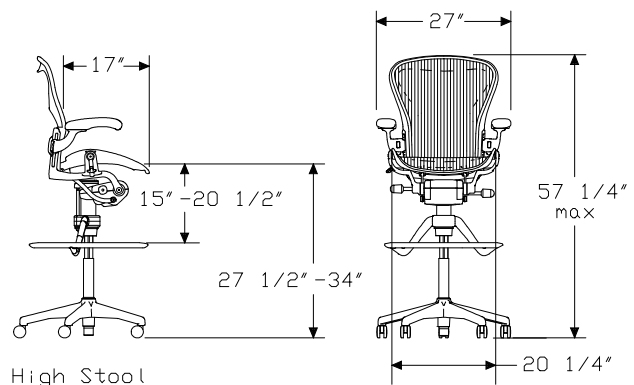

High Stool

Specification Information

Step 1.

AE7

Step 2. Height

- 1** low
- 2** high

Step 3. Tilt

- 1** standard tilt
- 2** tilt limiter
- 3** tilt limiter and seat angle

Step 4. Arms

- N** no arms
- P** fixed arms
- H** height-adjustable arms
- A** fully adjustable arms

Step 5. Armpad Upholstery

For no arms (N)

NB no arms

For fixed arms (P), height-adjustable arms (H), or fully adjustable arms (A)

- WB** nonupholstered armpads
- FB** leather armpads

Step 6. Base/Frame Finish

- G1** graphite base/frame
- XT** titanium base with smoke frame
- CD** polished aluminum base with graphite frame A

Prices for Steps 1-6.

		G1	XT	CD
AE711	N NB	\$1340	1340	1697
	P WB	\$1466	1466	1823
	FB	\$1511	1511	1868
	H WB	\$1529	1529	1886
	FB	\$1575	1575	1932
	A WB	\$1564	1564	1921
	FB	\$1609	1609	1966
AE712	N NB	\$1398	1398	1755
	P WB	\$1524	1524	1881
	FB	\$1569	1569	1926

H WB	\$1587	1587	1944
FB	\$1632	1632	1989
A WB	\$1621	1621	1978
FB	\$1667	1667	2024

AE713	N NB	\$1461	1461	1818
	P WB	\$1587	1587	1944
	FB	\$1632	1632	1989
	H WB	\$1650	1650	2007
	FB	\$1695	1695	2052
	A WB	\$1685	1685	2042
	FB	\$1729	1729	2086

AE721	N NB	\$1420	1420	1777
	P WB	\$1546	1546	1903
	FB	\$1592	1592	1949
	H WB	\$1609	1609	1966
	FB	\$1655	1655	2012
	A WB	\$1644	1644	2001
	FB	\$1690	1690	2047

AE722	N NB	\$1477	1477	1834
	P WB	\$1604	1604	1961
	FB	\$1650	1650	2007
	H WB	\$1667	1667	2024
	FB	\$1713	1713	2070
	A WB	\$1702	1702	2059
	FB	\$1748	1748	2105

AE723	N NB	\$1541	1541	1898
	P WB	\$1667	1667	2024
	FB	\$1713	1713	2070
	H WB	\$1729	1729	2086
	FB	\$1776	1776	2133
	A WB	\$1764	1764	2121
	FB	\$1811	1811	2168

Step 7. Back Support Option

For standard tilt (1)

- N2** no additional support +\$0
- AJ** adjustable lumbar support +\$60

For tilt limiter (2) or tilt limiter and seat angle (3)

- N2** no additional support +\$0
- AJ** adjustable lumbar support +\$60
- PJ** adjustable PostureFit® support +\$95

Step 8. Frame Applique

For graphite base/frame (G1)

NN	none	+\$0
ZB	graphite with graphite applique	+\$134

For titanium base with smoke frame (XT)

NN	none	+\$0
WS	titanium with smoke frame and smoke applique	+\$134

For polished aluminum base with graphite frame (CD)

NN	none	+\$0
G8	polished aluminum with graphite frame and graphite applique A	+\$134

Step 9. Casters/Glides

BB	2½" hard caster, black yoke, carpet	+\$0
GF	2½" glide, hard floors or carpet	+\$0
C7	2½" caster, black yoke, hard floors or carpet	+\$40
C9	2½" braking caster, black yoke, hard floors or carpet	+\$40

Step 10. Armpad Finish

For nonupholstered armpads (WB) with graphite base/frame (G1) or polished aluminum base with graphite frame (CD)

BK	black	+\$0
-----------	-------	------

For nonupholstered armpads (WB) with titanium base with smoke frame (XT)

S8	smoke	+\$0
-----------	-------	------

Step 11. Pellicle® Material

See application chart and textiles list for material usage and numbers. First 2 digits of number indicate material; remaining 2 digits indicate color.

Price Category 1	+\$0
Price Category 2	+\$25

Step 12. Armpad Leather

For fixed arms (P), height-adjustable arms (H), or fully adjustable arms (A) with leather armpads (FB)

See application chart and textiles list for fabric usage and numbers. First 2 digits of number indicate fabric line; remaining digit(s) indicate fabric color.

Price Category 7	+\$0
Price Category 9	+\$75

Side Chair

AE500

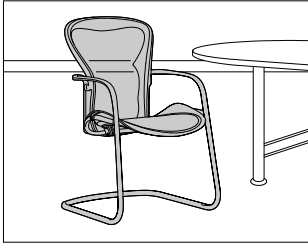

Product Information

Description

This side chair has a Pellicle® material that conforms to the user's body and retains its original shape when unoccupied. The material is lightweight and breathable and distributes the user's weight evenly over the seat and back of the chair. The chair has a sled base and fixed arms. It can be specified with optional lumbar support and with optional sled-base glides. The chair's size is based on the B-size Aeron work chair.

A fire retardant chair meets CAL 133 requirements. The chair's Pellicle material is manufactured with a fire-retardant additive. The additive does not meet Herman Miller's Design for the Environment criteria.

Notes

Side chair is tested and warranted for use by persons 300 pounds and under.

For information on glides, see Casters and Glides in Appendices.

Dimensions

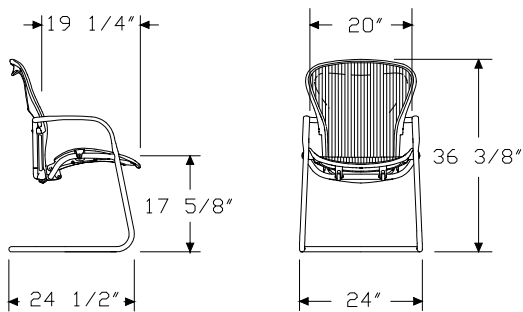

Specification Information

Step 1.

AE500P

Step 2. Fire Retardancy

For not fire retardant, skip this step.

FR fire retardant **A**

Prices for Steps 1-2.

AE500P	\$765
AE500P FR	\$765

Step 3. Lumbar Option

N2 no lumbar	+\$0
AJ adjustable	+\$60

Step 4. Base/Frame Finish

For not fire retardant

G1 graphite	+\$0
XT titanium with smoke frame	+\$0

For fire retardant (FR)

G1 graphite	+\$0
--------------------	------

Step 5. Glide Option

For graphite (G1)

NX no glide	+\$0
SB sled-base glide	+\$15

For titanium with smoke frame (XT)

NX no glide	+\$0
SB sled-base glide	+\$15

Step 6. Pellicle® Material

See application chart and textiles list for material usage and numbers. First 2 digits of number indicate material; remaining 2 digits indicate color.

For not fire retardant

Price Category 1	+\$0
Price Category 2	+\$25

For fire retardant (FR) with graphite (G1)

Price Category 1	+\$0
------------------	------

Aeron® Side Chair

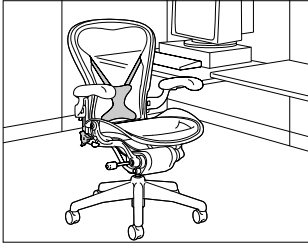

Aeron® Accessories

Product Information

Description

This PostureFit® support fits on the back of an A-, B-, or C-size Aeron work chair or B-size Aeron work stool. It provides a custom fit in the lower back area, below the beltline, that helps achieve healthier posture and improved lower back comfort. The user can adjust the level of support with a lever.

Graphite (G1) finish is recommended for use with the following chair or stool base/frame finishes:

- Graphite (G1)
- Graphite with graphite applique (ZB)
- Polished aluminum with graphite frame (CD)
- Polished aluminum with graphite frame and graphite applique (G8)

Smoke (S8) finish is recommended for use with the following chair or stool base/frame finishes:

- Titanium with smoke frame (XT)
- Titanium with smoke frame and smoke applique (WS)

Notes

Existing Aeron chair should include the tilt limiter option (tilt option 2 or 3) for optimal performance.

Specification Information

Step 1.

AE905

Step 2. Size

A	a size
B	b size
C	c size

Prices for Steps 1-2.

AE905 A	\$102
B	\$102
C	\$102

Step 3. Finish

G1	graphite	+ \$0
S8	smoke	+ \$0

Lumbar Kit

AE900

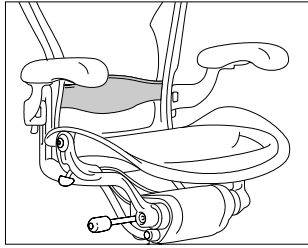

Product Information

Description

This lumbar pad fits into the back of an Aeron work chair or work stool to further support the lower back. The pad can be reversed to adjust for more or less support; one side of the pad is 3/4" and the other is 1 1/4".

Black (BK) lumbar pad finish is recommended for use with the following chair or stool base/frame finishes:

- Graphite (G1)
- Graphite with graphite applique (ZB)
- Polished aluminum with graphite frame (CD)
- Polished aluminum with graphite frame and graphite applique (G8)

Smoke (S8) lumbar pad finish is recommended for use with the following chair or stool base/frame finishes:

- Titanium with smoke frame (XT)
- Titanium with smoke frame and smoke applique (WS)

Notes

Specify lumbar pad size to match work chair size. For work stool, specify size B.

Specification Information

Step 1.

AE900NN

Step 2. Size

- A** a size
- B** b size
- C** c size

Prices for Steps 1-2.

AE900NN A	\$67
B	\$67
C	\$67

Step 3. Finish

BK black	+\$0
S8 smoke	+\$0

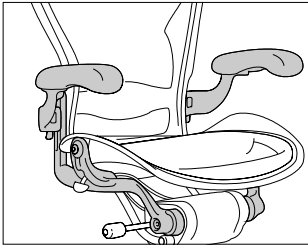

Product Information

Description

These arms can be retrofit to an Aeron work chair or work stool. Arm choices include a height-adjustable option that moves the arms 4" vertically and a fully adjustable option that moves the arms 4" vertically and pivots the armpads 15° outward and 17½° inward. Arm components are preassembled.

Notes

Customer's Own Leather (COL) requires 4 square feet. See Order Information in Appendices.

Dimensions



Fixed Arms



Height Adjustable and Fully Adjustable Arms

Aeron® Accessories

Specification Information

Step 1.

AE900

Step 2. Arms

- P** fixed arms
- H** height-adjustable arms
- A** fully adjustable arms

Step 3. Armpad Upholstery

- W0** nonupholstered armpads
- F0** leather armpads

Prices for Steps 1-3.

	W0	F0
AE900 P	\$128	174
H	\$240	284
A	\$274	318

Step 4. Finish

- G1** graphite +\$0
- XT** titanium +\$0
- CD** polished aluminum A +\$100

Step 5. Armpad Finish

For nonupholstered armpads (W0) with graphite (G1) or polished aluminum (CD)

- BK** black +\$0

For nonupholstered armpads (W0) with titanium (XT)

- S8** smoke +\$0

Step 6. Armpad Leather

For leather armpads (Fo)

See application chart and textiles list for fabric usage and numbers. First 2 digits of number indicate fabric line; remaining digit(s) indicate fabric color.

- Price Category 7 +\$0
- Price Category 9 +\$75

Frame Applique

AE910

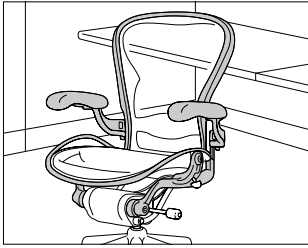

Product Information

Description

This frame applique is applied to an Aeron work chair or work stool's seat, back, and arms to minimize the effect of contact between the chair and a wood-edge surface. The seat and back appliques attach with the chair or stool's existing screws. Coated arm yokes replace existing arm yokes; arm components are preassembled. The arm yokes use the chair or stool's existing arm pads.

Frame applique does not meet CAL 133 requirements.

Notes

Order B- or C-size applique to retrofit work chair; order B-size appliqué to retrofit work stool.

Specification Information

Step 1.

AE910

Step 2. Arms

- P** fixed arms
- H** height-adjustable arms
- A** fully adjustable arms

Step 3. Size

- B** b size
- C** c size

Prices for Steps 1-3.

		B	C
AE910	P	\$281	281
	H	\$295	295
	A	\$300	300

Step 4. Finish

- WS** titanium with smoke frame and smoke applique +\$0
- ZB** graphite with graphite applique +\$0

For more information about our products and services or to see a list of dealers, please visit us at HermanMiller.com or call (800) 851 1196.

This book is recyclable. Printed in U.S.A. on recycled paper.

© 2010 Herman Miller, Inc., Zeeland, Michigan

® **HermanMiller**, ☉, Abak, AO, Action Office, Aeron, Ambi, Ardea, Aside, Avive, Babble, C2, Caper, Celle, Co/Struc, DOT, Eames, Embody, Envelop, Equa 2, Ergon 3, Ethospace, Fine-Tune, FlexFront, Formcoat, Ground Cloth, Herman Miller Healthcare, Herman Miller Options, Intersect, Kinemat, Leaf, Lifework, Limerick, Meridian, Mirra, Passage, Pedastool, Pellicle, Perspectives, PostureFit, Prospects, Quadrant, Reaction, Resolve, RoomTune, Scooter, Stoa, Teneo, Vary Easy, Vivo, and Z-Axis are among the registered trademarks of Herman Miller, Inc., and its owned subsidiaries.

™ About Face, AireWeave, Airia, Arrio, Backfit, Boomerang, Bubbletack, Burdick Group, Celeste, Cellular Suspension, Clam, CLT, CoActive, Cognita, Compass, Cygnus, daisyone, Enchord, EnhancedAccess, E-Wall, Flex-Edge, Flute, Harmonic, Herman Miller for the Home, Herman Miller International Collection, Herman Miller Select, Hopsak 2, Intent, Iota, JAW, Keyless Entry, Lapjack, Latitude, LOOP, Lyris, Multiscrim, My Studio Environments, Nala, Nelson, Pixelated Support, Programmable Environments, Q, Rapunzel, Recline Selector, S3, Sense, Setu, Stackable, Stackable Storage, TaskPointe, The Be Collection, Thinking is good for you, TriFlex, Tu, Twist, V-Wall, and Wishbone are among the trademarks of Herman Miller, Inc., and its owned subsidiaries.

SM TAP, Textile Alliance Program, Thoughtpile, and Thrive are among the service marks of Herman Miller, Inc.

Chemsurf® is a registered trademark of Wilsonart International.

Corian® is a registered trademark of DuPont.

FLEXNET™ is a trademark of Milliken & Company.

Floor Saver Glide® is a registered trademark of Carpin Manufacturing, Inc.

Geiger® is a registered trademark of Geiger International.

Goetz™ is a trademark of Mark W. Goetz.

Hang-It-All® is a registered trademark of Lucia Eames Demetrios, d.b.a. Eames Office.

Holophane® is a registered trademark of Holophane.

Ingeo™ is a trademark of Cargill Dow LLC.

Microsoft® and Natural® Keyboard are registered trademarks of Microsoft Corporation.

Noguchi® is a registered trademark of The Isamu Noguchi Foundation and Garden Museum.

Qt Quiet technology™ and Qt™ are trademarks of Cambridge Sound Management, Inc.